



Installation and Basic Operation Manual

MTU Onsite Energy Corporation
100 Power Drive, Mankato, MN 56001
Phone 800-325-5450 www.mtu-online.com
Installation_Basic_Manual_MTU_8-09

CALIFORNIA PROPOSITION 65

WARNING

ENGINE EXHAUST FROM THIS PRODUCT CONTAINS CHEMICALS KNOWN TO THE STATE OF CALIFORNIA TO CAUSE CANCER, BIRTH DEFECTS, AND OTHER REPRODUCTIVE HARM.



Contents

Contents.....	3
Product Identification Information.....	4
Forward.....	5
Figures and Tables.....	6
Safety Precautions	7
General	13
Lifting Provisions	14
Location.....	15
Mounting	16
Air Requirements	19
Exhaust System	23
Fuel System	27
Electrical Requirements	35
Service	41
Installation Checklist.....	42
Start-Up Request Form	43
Operating Procedures	44
Troubleshooting	51



Product Identification Information

Locate and record numbers in the spaces below immediately after unpacking your generator set. This ensures that the numbers are readily available for future reference.

Model Designation: _____

Serial Number: _____

HOW TO READ MODEL NUMBERS

MTU Onsite Energy's model numbering format is composed of 7 sections:

60 * J S 6 D T 2

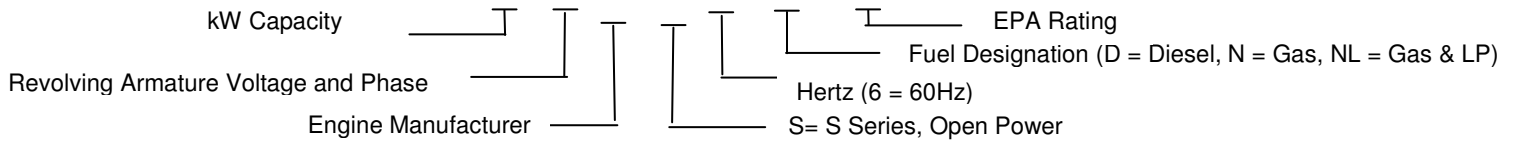



Forward

This Installation Guide provides general instructions for installing your MTU Onsite Energy generator set properly. It is essential that every person who works on or with the generator set be completely familiar with the contents of this manual, and that he/she carefully follows the instructions contained herein.

Each installation may require some modification of the suggested guidelines in this manual. Installations must be consistent with locally applicable standards and take into consideration safety guidelines and measures.

Following this guide will result in an efficient and reliable installation. Carefully follow all procedures and safety precautions to ensure proper equipment operation and to avoid bodily injury. Read and follow the Safety Precautions section at the beginning of this manual.

IMPORTANT

Information in this publication represents data available at the time of print. MTU Onsite Energy reserves the right to change this publication and the products represented without notice and without any obligation or liability whatsoever.

All instructions and diagrams have been checked for accuracy and simplicity of application. However, the skills of the installer are most important. MTU Onsite Energy does not guarantee the result of any installation contained in this manual. Nor can MTU Onsite Energy assume responsibility for any injury or damage to property. Persons engaging in installation do so entirely at their own risk.



Figures and Tables

The following is a list of all figures and tables contained in this manual.

Figure 1-1.....Typical generator set installation
 Figure 2-1.....Lifting provisions
 Figure 4-1.....Typical pad type vibration
 Figure 4-2.....Spring mount vibration isolator
 Figure 4-3.....Recommended anchor bolt
 Figure 5-1.....Typical center top pivoted louver
 Figure 5-2.....Typical installation with louvers
 Figure 5-3.....Typical remote radiator installation
 Figure 6-1.....Typical side inlet exhaust
 Figure 6-2.....Typical end inlet exhaust
 Figure 6-3.....Wall thimble installation
 Figure 7-1.....Fuel day tank
 Figure 7-2A.....Gaseous fuel pipe schematic
 Figure 8-1.....Suggested motorized louver wiring
 Figure 8-2.....Optional motorized louver wiring
 Figure 12-1.....Standard GAC Governor Control
 Figure 12-2.....Standard Mechanical Governor (Diesel)
 Figure 12-3.....Standard Mechanical Governor (Diesel)

Table 6-1.....Equivalent lengths of pipe fittings
 Table 7-1.....Gaseous fuel pipe capacity

Safety Precautions

IMPORTANT SAFETY INSTRUCTIONS

Electromechanical equipment, including generator sets, transfer switches, switchgear, and accessories, can cause bodily harm and pose life-threatening danger when improperly installed, operated, or maintained.

Dangers, Warnings and Cautions are used in this manual to alert the operator to special instructions concerning a particular procedure that may be hazardous if performed incorrectly. These safety alerts alone cannot eliminate the hazards that they signal. Strict compliance to these special instructions and common sense operation are major accident prevention measures. Observe all warnings found on the equipment. Ensure that warning labels are legible and not obstructed by dirt, grease or other equipment. MTU Onsite Energy cannot anticipate every possible circumstance that might involve a hazard. The warnings in this manual and on tags and decals affixed to equipment are, therefore, not all inclusive.



DANGER

Danger indicates the presence of a hazard that will cause severe personal injury, death, or substantial property damage.



WARNING

Warning indicates the presence of a hazard that can cause severe personal injury, death, or substantial property damage.



CAUTION

Caution indicates the presence of a hazard that will or can cause minor personal injury or property damage.



This symbol signifies high voltage.

The following safety rules should be strictly complied with:

ACCIDENTAL STARTING

Be aware that the generator set could start at any time in the “AUTO” mode. Keep clear of all moving parts and be sure to turn switch to the “OFF” position before servicing and disconnect the negative battery cable after disconnecting the battery charger circuit.

BATTERY

For proper unit operation, battery minus (-) terminal must always be connected to ground. Reverse connection of the battery will severely damage or destroy the battery charging alternator, regulator and other polarity sensitive devices.

Wear protective safety eyeglasses and gloves when handling starting batteries and electrolyte. Battery acid can cause serious burns if it contacts eyes or skin.

Servicing of batteries is to be performed or supervised by personnel knowledgeable of batteries and the required precautions. Keep unauthorized personnel away from batteries.

Do not smoke or use an open flame when servicing batteries. Batteries generate an explosive gas during charging.

The replacement starting battery or batteries must be of equal size and cold cranking amps.

The generator controls must be in the off position when replacing the batteries.

Do not dispose of battery or batteries in a fire. The battery is capable of exploding.

Do not open or mutilate the battery. Released electrolyte has been known to be harmful to the skin and eyes and to be toxic.

A battery presents a risk of electrical shock and high short circuit current. The following precautions are to be observed when working on batteries:

1. Remove watches, rings, or other metal objects
2. Use tools with insulated handles

VENTED BATTERIES

The installation of the engine generator shall provide enough ventilation to ensure that gases generated by vented batteries during charging or caused by equipment malfunction are removed.

The electrolyte is a dilute sulfuric acid that is harmful to the skin and eyes. It is electrically conductive and corrosive. The following procedures are to be observed:

1. Wear full eye protection and protective clothing
2. Where electrolyte contacts the skin, wash it off immediately with water
3. Where electrolyte contacts the eyes, flush thoroughly and immediately with water
4. Spilled electrolyte is to be washed down with an acid-neutralizing agent. A common practice is to use a solution of 1 pound (500 grams) bicarbonate of soda solution to be added until the evidence of reaction (foaming) has ceased. The resulting liquid is to be flushed with water and the area dried.

Lead acid batteries present a risk of fire because they generate hydrogen gas. The following procedures are to be followed:

1. DO NOT SMOKE when near batteries

2. DO NOT cause flame or spark in battery area
3. Discharge static electricity from body before touching batteries by first touching a grounded metal surface

FIRE HAZARD

Keep fire extinguishers in accessible locations. Use appropriate fire extinguishers as recommended by NFPA.

Remove all unnecessary grease and oil from the unit. Accumulated grease and oil can cause overheating and engine damage, which present a potential fire hazard.

When an open bottom base is used, the stationary engine generator assembly is to be installed over noncombustible materials. It should be located such that it prevents combustible materials or loose debris from accumulating under or inside the generator set.

Do not service the engine when any ignition source such as an open flame is present. "DANGER" signs must be placed to warn of the fire hazard. No work may be performed on the engine involving an ignition source such as open flames, cutting, welding, or grinding.

A fire extinguisher (dry chemical or carbon dioxide, CO₂) must be immediately available to the mechanics while working. When liquefied or natural gas leaks or escapes, it can result in dangerous accumulations of gas, which might cause a serious flash or explosion. Careful ventilation of the area is mandatory in the event of a fuel leak.

EXHAUST SYSTEM

Engine exhaust gases contain DEADLY carbon monoxide gas, which is colorless and odorless. If breathed in sufficient concentrations, this gas can cause severe nausea, fainting, or death. Provide adequate ventilation to prevent buildup of exhaust gases. When the generator is installed inside a room or enclosure, exhaust gases must be piped outdoors. Install the exhaust system so exhaust gas does not leak at joints or piping connections. Make certain that the extended exhaust piping is plumbed properly and that the exhaust is not near an intake ventilator.

Increase the exhaust pipe diameter as necessary to reduce back pressure. Use a minimum number of fittings and elbows to prevent back pressure in the engine exhaust system. Be sure the enclosure has proper ventilation to accommodate the engine cooling system.

FUEL SYSTEM

Gaseous, Natural Gas and Liquid Propane Gas are extremely flammable, and vapors are EXPLOSIVE. Comply with all laws regulating the storage and handling of these fuels. Check for leaks frequently and correct such leakage immediately.

Do not fill fuel tanks while the engine is running.

Do not smoke or use open flame at any time when fuel is being handled. Fuel vapors are both toxic and flammable.

Liquid petroleum gas (LPG) systems operate at tank pressures around 100 psi or above. The tank pressures are regulated down. Vaporized LPG systems operate at pressures near 6 oz., as do most natural gas systems.

Safety precautions when handling liquefied petroleum gas cannot be over-emphasized. There are state, county and city codes, and fire regulations covering the handling and storage of liquefied petroleum gas or natural gas. In addition to the safety suggestions in this manual, all local codes and fire regulations on this subject must be followed explicitly. Where local codes are more stringent than the suggestions in this manual, the local codes must be given priority.

Before proceeding with any service, be certain that all switches are in the OFF position, disconnect battery ground cable, remove fuses in DC systems and turn off the battery charger. These safety suggestions apply to service of any engine using liquefied petroleum gas or natural gas fuel regardless of the work to be performed. When servicing the engine, ensure that there is adequate ventilation. This is to avoid the accumulation of gas/air mixtures in and about the engine caused by undetected leaks.

Any service performed on the fuel system requires that:

- All threaded connections are sealed with proper pipe thread compound. Replace defective fittings and reseal all connections.
- Fuel system is checked for leaks. Leaks are not permissible. Odorants, which are strong smelling components (an odor similar to spoiled cabbage), are added to liquefied petroleum gas as a warning agent to indicate the leakage of even small quantities of gas.
- A soap solution applied with a soft brush will bubble to indicate leaks. Never use an open flame to check for leaks. All leaks must be sealed.
- All flexible fuel connections are checked, metallic and neoprene, with the soap solution.

It is important to remember that all gas fuel systems are pressurized. Be certain that the fuel valves are tightly closed and all fuel has been vented before starting any repair work on the fuel system.

HAZARDOUS NOISE

Prolonged unprotected exposure to hazardous noise levels may cause loss of hearing. Never operate the generator set without a muffler or with a faulty exhaust system. Ear protection may be required.

HAZARDOUS VOLTAGE/ELECTRICAL SHOCK

Dangerous voltages are present at power terminals of this equipment. Contact with such terminals will result in extremely dangerous and possibly lethal electric shock. Never allow any unqualified person to install, operate or service the equipment. The standby electric system must be installed, tested, and inspected per the manufacturer's recommendations. All codes, standards, regulations, and laws pertaining to the installation must be strictly complied with.

Accidental contact with electrical equipment can cause severe injury and death if the equipment is not properly grounded. The frame and external electrically conductive parts of this equipment must be properly connected to an approved earth ground, in accordance with applicable electrical codes. A grounding lug is provided on the generator and in other equipment for this purpose.

CAUTION: RISK OF ELECTRIC SHOCK!

The grounded conductor must be bonded to ground in accordance with the National Electrical Code, NFPA 70. The unit shall not be used in floating output applications.

Remove all electrical power before removing protective shields for service or maintenance. Exercise extreme caution when working on or around electrical components. Open or poorly insulated conductors are extremely dangerous during operation. Severe, possibly fatal, shock may result. Make certain that all conductors are properly insulated or guarded, all grounds are made and that the area is dry. Do not tamper with interlocks.

In the event of an accident from electrical shock, shut down the generator set immediately. If the set cannot be shut down, free the victim from contact with a dry nonconductor, avoiding direct contact with victim until free of the conductor. If the victim is unconscious, apply artificial respiration if qualified and get medical help immediately.

Verify that all power leads and control connections are properly insulated before starting the generator set. Neglecting this may result in extensive damage to equipment and personal injury. This problem arises if the unit is started before electrical installation is completed.

Make certain the area is well ventilated to dissipate any flammable vapors, which may collect from fuels. When servicing any part of the electrical system or making any connections, be sure the main switch is OFF and disconnect battery ground cable or remove fuse in DC system. Turn off the battery charger. Clean or service the generator set only when the engine is shut down. If the unit stops because of an engine safety device, do not attempt to restart until the cause for shutdown has been corrected.

HOT PARTS

The exhaust manifold, turbocharger(s), and extended exhaust piping are HOT when the engine is running. These can remain hot for long periods of time after the engine shuts off. Avoid contact with these parts. Consider insulating the exhaust system if installation is such that unintentional contact with the exhaust system components is likely.

Coolants under pressure have a higher boiling point than water. DO NOT open a radiator or heat exchanger pressure cap while the engine is running. Allow the generator set to cool and bleed the system pressure first.

MOVING PARTS

Moving parts can cause severe personal injury or death. Do not wear loose clothing or jewelry in the vicinity of moving parts, or while working on electrical equipment. Loose clothing and

jewelry can become caught in moving parts. Jewelry can short out electrical contacts and cause shock or burning.

HANDLING

Do not use lifting devices with marginal capacities when lifting or moving the unit. Observe the center of gravity of the equipment to be lifted and do not allow the generator set to swing if suspended. Make certain the supporting structure is adequate to support the unit. Failure to observe this warning may result in equipment damage and serious or fatal injury.

1

General

When installed properly and according to applicable codes, your MTU Onsite Energy generator set will perform safely and reliably. Incorrect installation can cause continuing problems. Figure 1-1 illustrates a typical installation. Your authorized generator set distributor/dealer can provide advice about or assistance with your installation.

This manual references organizations and their codes that govern generator set selection and installation for US installations. Installers must comply with national and local codes when applicable.

- NFPA 37.....Stationary Engines and Gas Turbines
- NFPA 54.....National Fuel Gas Code
- NFPA 70.....National Electric Code®
- NFPA 99.....Standard for Health Care Facilities
- NFPA 101.....Life Safety Code
- NFPA 110.....Emergency Standby Power Systems
- UL-2200.....Stationary Engine Generator Assemblies

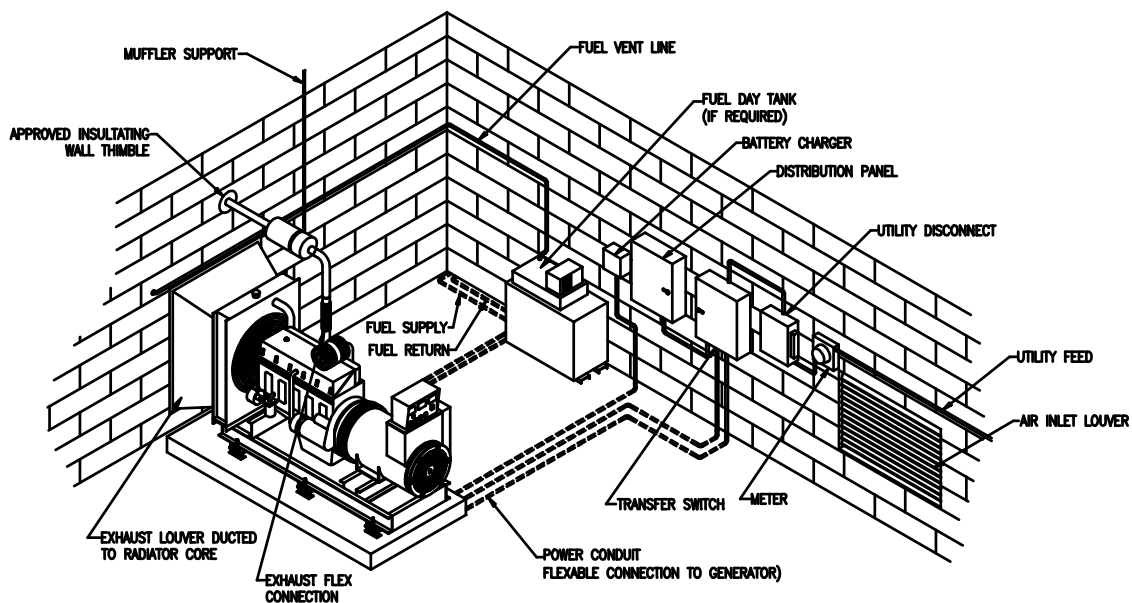

Figure 1-1: Typical generator set installation

2

Lifting Provisions

To ensure personal safety and prevent damage to the product, we strongly recommend the guidelines in Figure 2-1 be observed when lifting MTU Onsite Energy generator sets. Due to the different designs, dimensions and weights of the generator sets, specific instructions for each model are not provided. It is the responsibility of the dealer/distributor to see that generator set lifting is performed within the framework of these guidelines.

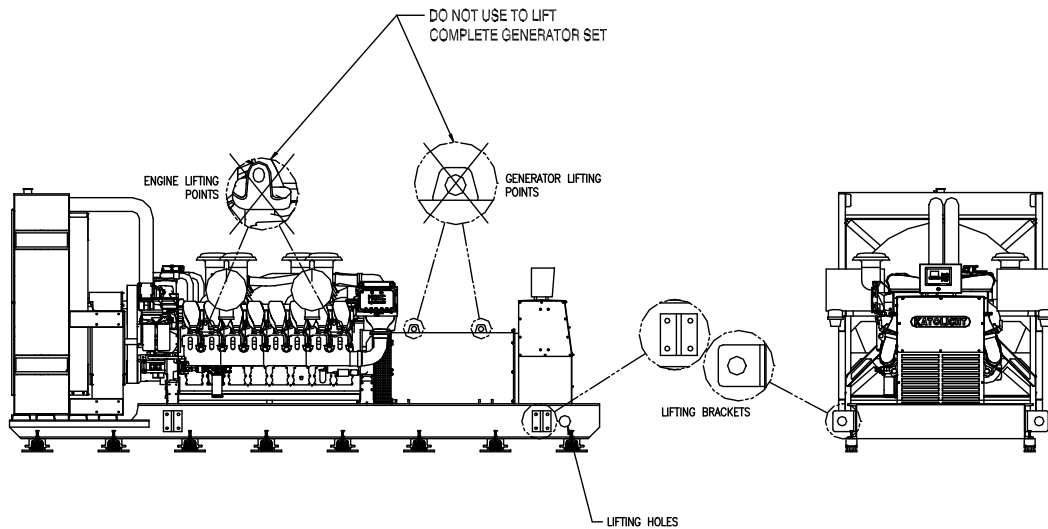

Figure 2-1: Lifting provisions

3

Location

The location of the generator set is influenced by factors such as ventilation, exhaust piping, electrical service, fuel supply and accessibility for maintenance and service.

Before selecting the location for your generator set, consider the following:

- Supporting structure must be adequate for the generator set and accessories. For information on mounting on an inertia pad, see Section 4. For any other set-up, consult a structural engineer for an appropriate design.
- Area should be clean, dry and not subject to flooding.
- Ventilation should be available in the area with a minimum amount of duct work
- Exhaust gas must be piped away from the structure and any ventilation intakes. Piping must incorporate large radius, low restriction elbows.
- An adequate supply of fuel should be available at all times to sustain operation.
- The main diesel fuel supply should be as close as possible to the unit. If the main fuel tank is installed underground, an auxiliary pump and day tank are necessary to transfer fuel from the main tank to the day tank.
- Vibration should be effectively isolated and dampened to reduce transmission of vibration and prevent fatigue fractures of connected systems.
- Area should provide easy access for maintenance and repair. A minimum clearance of 3 feet between an installed generator set and adjacent walls or other electrical equipment should be maintained on 3 sides of the generator set. Clearance of 5 feet should be maintained at the rear of the generator set to facilitate removal, should it become necessary.
- Applicable fire rating codes and standards must be met.
- When an open bottom base is used, the stationary engine generator assembly is to be installed over noncombustible materials. It should be located such that it prevents combustible materials or loose debris from accumulating under or inside the generator set.

Local weather conditions will have a direct influence on location of the unit and the type of accessory equipment required to assure reliable operation. Extreme ambient temperature variations should be avoided. For ambient temperatures below 60 degrees, starting aids such as jacket water heaters and lubricating oil heaters will ensure dependable starting. Anti-condensation or strip heaters are available for control panels and generators to maintain a temperature above the dew point to prevent condensation of moisture.

Standard transfer switches located indoors in heated facilities are enclosed in NEMA 1 enclosures. Various other NEMA enclosures may be needed. If the generator set is located outside, heaters are needed below 32 degrees Fahrenheit.

Consider preventive maintenance issues when selecting a generator set location. See Section 9 for a list of service points that should be accessible.

4

Mounting

Your generator set should be installed in a location that is able to support the weight of the unit and accessories, resist dynamic loading, and does not transmit generator noise and vibration. See Section 3 for detailed information on selecting a location for your generator set.

FIELD ALIGNMENT

Field alignment after the generator set is installed corrects any changes in the coupling alignment during transport and installation. This realignment ensures that the coupling will perform as needed and reduces the possibility of excess vibrations that decrease the useful life of the generator set.

After final installation, the following measurements must be checked to confirm proper alignment as noted in the table and illustration below:

Measurement	Specification
Angular Displacement	Less than or equal to .3°
Radial Displacement	Less than or equal to .059 inches
Axial Displacement	Less than or equal to .157 inches

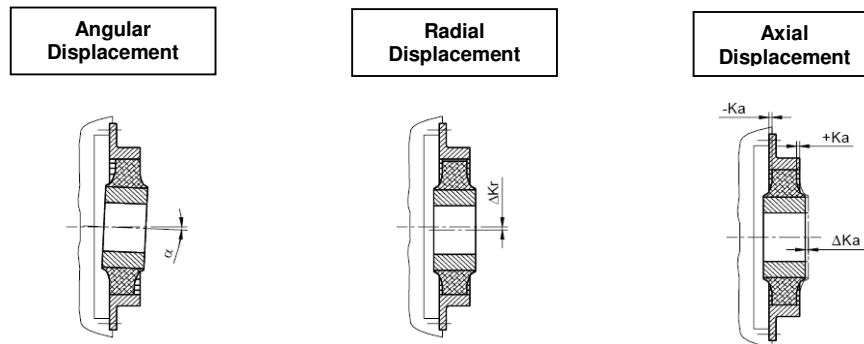

Alignment can be validated by using dial indicators or a laser alignment tool.

NOTE: This applies only to models equipped with a two-bearing generator.

ENGINE LOCKS

All generator sets must be locked using the crankshaft locks provided with the engine by the engine manufacturer. If the generator sets are using vibration isolators, these must be blocked as well. Before installing the generator set, these engine locks and vibration isolator blocks must be removed.

NOTE: This effects S4000 engine serial numbers beginning with 526, 527, and 528.

WEIGHT

The weight of the generator set and accessories will determine the type and design of the support structure. Generator set weight can be found in the specification sheet for your particular model. Be sure that the weight of accessory items and fuel (if a sub-base tank is used) are added to the total requirements.

INERTIA PAD/BASE

Your generator set must be mounted on a substantial inertia pad or base. The composition of the inertia pad should follow standard practice for the required loading. Common specifications call for 2500 psi concrete reinforced with 8-gage wire mesh or number 6 reinforcing bars on 12-inch (30-cm) centers.

To determine the depth of the inertia pad, the following formula can be used:

BASE DEPTH =	$\frac{W_u}{d * w * l}$
-----------------	-------------------------

- Where W_u = engine-generator set weight in pounds
- d = concrete density (usually 145 lbs per cubic foot)
- w = foundation width in feet
- l = foundation length in feet

The inertia pad should be a minimum of 12 inches wider and 12 inches longer than the unit base. The inertia pad may be constructed higher than the floor level by 3 to 8 inches for ease of maintenance.

To reduce the amount of unit vibration transmitted, you must isolate your inertia pad from the foundation. One method for isolating the inertia pad from the foundation is to use 8 to 10 inches of wet gravel or sand as a bed in the inertia pad pit. For other methods, consult a qualified structural engineer.

To allow settlement of the inertia pad from the foundation, expansion joints should be incorporated between the inertia pad and the foundation.

VIBRATION ISOLATION

Vibration is a normal by-product of the operation of any generator set. Vibration transmitted to surrounding areas will increase the noise level and if severe, can cause structural damage. To minimize this risk, all generator sets should have vibration isolation between the generator base and inertia pad.

All fuel, coolant, exhaust and electrical connections must have flexible sections to isolate vibration. Leaks or fractures can develop rapidly without vibration isolation and there is a danger of eventual total failure.

For generator sets enclosed within a building, where maximum vibration isolation is required, spring mounts provide vibration isolation between the generator base and the structure.

Check state and local codes for such requirements.

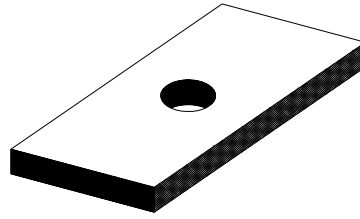

Figure 4-1: Typical pad type vibration

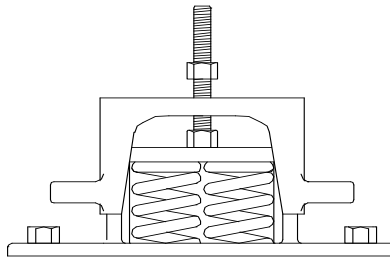

Figure 4-2: Spring mount vibration isolator

Anchor bolts should be loosened and double nipped after installation to avoid base distortion caused by unlevel inertia pads.

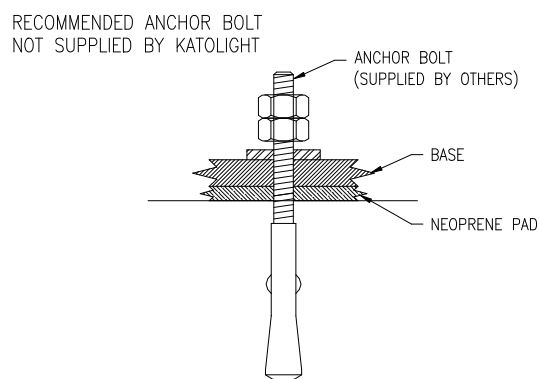

Figure 4-3: Recommended anchor bolt

5

Air Requirements

GENERAL

When installing engine generator sets, great care must be taken to ensure adequate ventilation. Proper installations require enough ventilation to cool the engine generator set as well as supply adequate air for combustion.

When installing the ventilation system, the following factors should be considered:

- Location of intake and exhaust louvers
- Method of actuation of intake and exhaust louvers
- Ambient temperature
- Routing of exhaust air duct

The air intake and exhaust should be in line to provide engine room ventilation air flow which will parallel the generator set air flow over the engine, through the radiator and/or exhaust louver. The inlet and outlet openings must be large enough to provide the volume of air required by the engine generator.

NOTE

Exhaust louver effective opening should be at least 25% to 50% larger than engine radiator core. Intake louver should be 50% to 100% larger in effective opening than engine radiator core.

In most applications, intake and exhaust louvers should be used. Figure 5-1 indicates a typical louver.

Care should be taken to provide adequate open space outside the exhaust louver so as not to obstruct airflow.

Units with mounted radiators should be installed with ducting between the radiator and the exhaust louver to prevent recirculation of air.

CAUTION

Ensure that the exhaust ducting is installed so that no recirculation of radiator exhaust air occurs. Failure to prevent recirculation could cause the unit to overheat and shut down.

The exhaust louver should not be exposed to high prevailing winds, since wind pressure may reduce fan discharge and reduce cooling. The duct should be constructed with as few bends as possible. All units can be supplied with radiator duct flanges of the required size to meet the customer's application.

If bends are required, they should be in the form of gradual sweeps to allow airflow with minimum restriction. Increase duct size one-fourth to one-half to compensate for bends.

Motorized and gravity louvers may be used to prevent entry of cold air which may cause difficulty in engine starting. (Refer to Chapter 8 for recommendations for wiring motorized louvers). Louvers also reduce the entry of rain, snow and insects into the building.

A gravity-operated louver can be used for the exhaust air. When the set operates, outlet airflow will open the louver and it will close automatically by gravity when the unit is shut down.

Generating sets with automatic start require the use of motor operated intake or fixed louvers or dampers. Motor operated louvers are held closed by spring tension and are driven to the open position by a motor operating through a mechanical linkage.

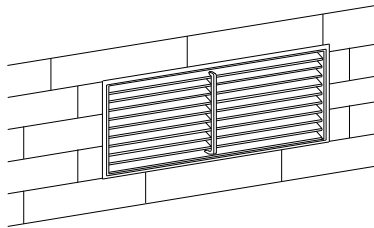

Figure 5-1: Typical center top pivoted louver

CAUTION

Care should be taken in wiring the system to ensure that the intake louver motor is supplied with power during all possible modes of unit operation, i.e. true power failure, simulated power failure due to incorporation of a system test switch, or automatic plant exercising. Incorrectly wired louver motors could result in the louvers closing prematurely during engine cool-down, which can cause overheating, engine shutdown, and possible damage to the unit.

In some extreme cold weather applications, the opening of intake louvers immediately upon starting may cause carburetor icing and vaporizing problems with engines utilizing gaseous fuels. Diesel engines may also be affected if lightly loaded. Thermostatically controlled louvers may be used to reduce the difficulties encountered with cold weather applications.

Figure 5-2 illustrates a typical generator set installation for units with unit-mounted radiators, indicating ducting and preferred locations of the louvers.

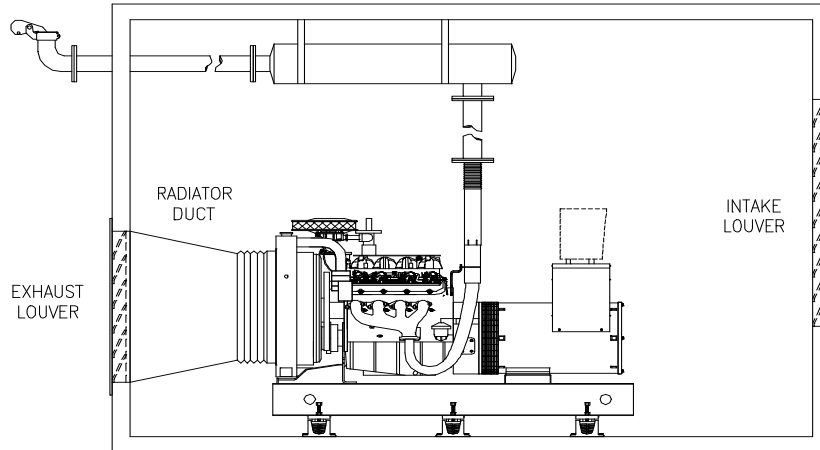

Figure 5-2: Typical installation with louvers

Engine-generator sets with remote cooling will not have an engine driven fan to move air through the generator room. As a result, a fan or some other means of moving air through the room must be considered. The fan must move the required amount of air against the allowable static friction.

The following formula may be used to estimate the amount of airflow required to remove engine and generator radiated heat and supply sufficient combustion air. The formula is based on air temperature of 100°F. Allowable room air temperature rise is 20° to 30° F.

$$V = \frac{Q}{0.018 \cdot \Delta T}$$

Where V = Air flow through the engine-generator room (CFM)
 Q = Engine-generator set radiated heat (BTU/min)
 ΔT = Allowable room air temperature

Higher elevation installations will require increased airflow. Add 10% for each increase of 2500 feet. Also increase airflow for non-insulated exhaust silencer and other equipment that may add to the radiated heat in the room. Also keep in mind the required combustion airflow for the engine.

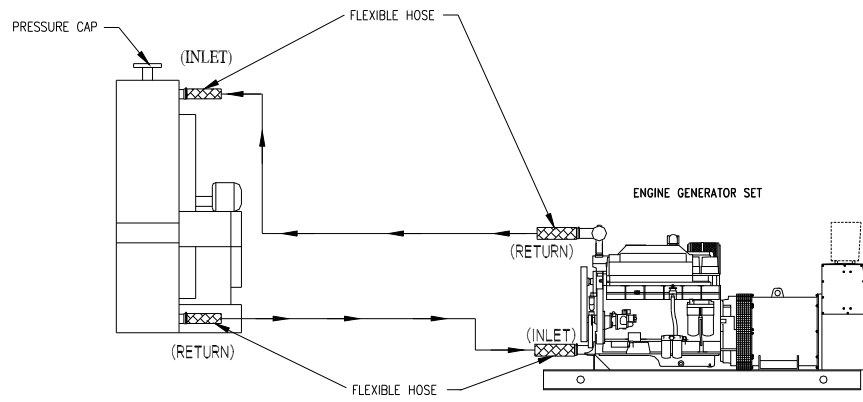

Figure 5-3: Typical remote radiator installation

6

Exhaust System

Proper exhaust system installation is essential for maximum generator set engine efficiency. Because exhaust fumes are deadly, great care must be taken when installing the exhaust system. Consideration must be given to back pressure, piping, and placement. Figures 6-1 and 6-2 show the general arrangement of recommended exhaust systems.

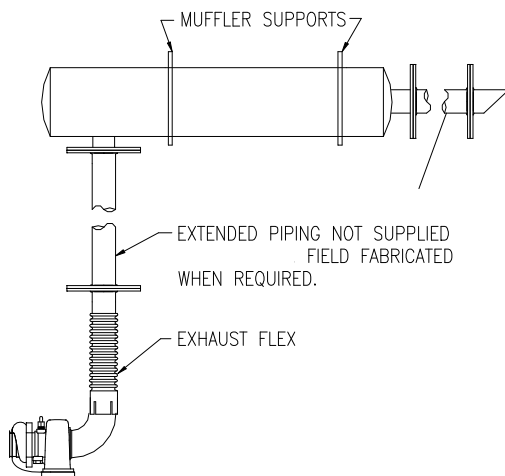

Figure 6-1: Typical side inlet exhaust

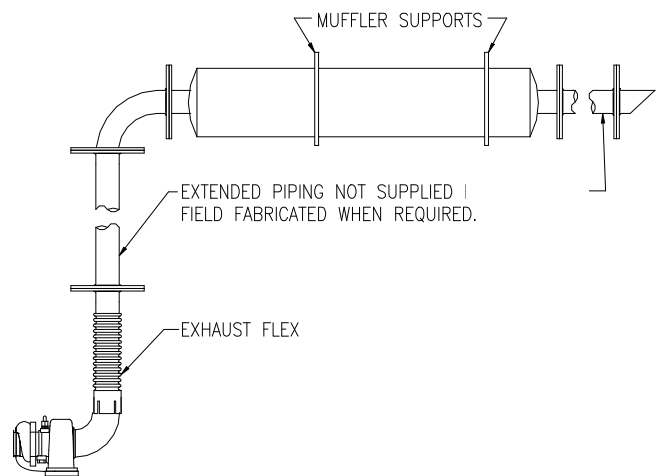

Figure 6-2: Typical end inlet exhaust

PLACEMENT

The exhaust pipe should terminate outdoors, away from doors, windows, or other building openings in an area where exhaust can dissipate. Placement of piping and exhaust silencer should take into account the location of combustible materials. If location cannot avoid these concerns, remove combustible materials on a regular basis. Keep dry grass, foliage, and combustible landscaping material a safe distance from the exhaust system.

WARNING

Inhalation of exhaust gases can cause death. Exhaust pipes must not terminate near fresh inlet vents of any type or near combustible materials. Avoid exhaust gas recirculation which could cause the engine-generator set to overheat. Generator sets installed outdoors inside enclosures should have their exhaust directed so that it will disperse away from buildings and building air intakes.

BACK PRESSURE

The installed exhaust system must not exceed the engine manufacturer's maximum exhaust back pressure limit. Damage may result from excessive back pressure. Causes may include:

- Insufficient exhaust pipe diameter
- Exhaust run too long

- Exhaust silencer too small or designed improperly
- Too many bends and/or constrictions in piping
- Obstruction in exhaust piping

Your generator set has been sized so that exhaust system back pressure is kept within the acceptable limits. However, in situations when extended piping or a flex connector other than the one supplied must be used, contact MTU Onsite Energy to ensure that back pressure will not exceed the engine manufacturer's specification.

PIPING

Exhaust piping must conform to all applicable codes. Routing of exhaust piping should be as short and direct as possible. Exhaust piping should be of Schedule 40 black iron, steel or other suitable material having adequate strength and durability. The recommended material for exhaust piping is Schedule 40 black iron pipe. Where possible, sweep elbows with a radius of at least 3 times the pipe diameter should be used.

Exhaust pipes must be independently supported with no weight applied to the engine, turbocharger, exhaust manifold or flex connector. Where exhaust pipes attach to the engine, they must be connected with flexible connectors to minimize vibrations that can cause damage to the exhaust system.

CAUTION

Weight applied and vibration extended to the exhaust manifold or turbocharger could result in damage to these components. No exhaust piping weight may be carried by the engine, exhaust manifold or turbocharger.

FLEXIBLE SECTION

The supplied exhaust flex should be installed directly off the engine turbo elbow/manifold. This limits the stress on the engine exhaust manifold or turbocharger resulting from engine motion on its vibration mounts and temperature-induced changes in pipe dimensions. The flexible section should not be bent or used to make up for misalignment between the engine exhaust and the exhaust piping. Since typical exhaust temperatures range from 800~F (427~C) to over 1200~F (649~C) for some engines, seamless stainless steel should be used for the flexible section.

CAUTION

When installing a silencer, make certain flow direction is correct. Check inlet and outlet marking on the silencer nameplate.

EXTENDED PIPING

Engine exhaust piping can accumulate a considerable amount of condensed moisture after unit shutdown, particularly if the exhaust system is run through lengthy piping. To prevent condensed moisture from running back into the engine, exhaust piping should be sloped away from the engine and a condensate trap and drain should be incorporated at a low point ahead of engine manifolds. The trap should be drained periodically.

Horizontal extended exhaust pipe should terminate with a 45° tail pipe to prohibit rain from entering the system. A screen should be placed across the end of the tail pipe to keep birds and rodents from entering the system.

Where vertical exhaust stack is necessary, a rain cap should be fitted to exclude rain and snow from the exhaust pipe.

Where there is a danger of extending piping coming in contact with combustible material or personnel, the piping should be insulated or shielded.

PIPING INSULATION

The heat rejected by exhaust piping and the amount of ventilating air required can be substantially reduced by insulating exhaust piping with suitable high-temperature insulation. Exhaust temperatures are given on each generator model's specification sheet. **DO NOT** insulate piping for the turbocharger or manifold.

WALL OR ROOF THIMBLES

Exhaust piping passing through combustible walls or partitions must be guarded at the point of passage by an approved metal ventilated thimble to prevent exhaust pipe heat from being transmitted to the combustible material (Figure 6-3). Thimbles must be suitable for the application. Consider the type of exhaust system, construction materials used and local fire codes.

ROOF THIMBLES

Approved roof thimbles should be constructed so that they extend at least (9) inches both ways from the surface of the roof. Ventilation holes are located on both ends for roof thimbles, therefore, a rain shield must be included above the thimble. Rain caps on the end of the exhaust pipe are recommended only in areas not subject to freezing temperatures. In an area where freezing is common, extend the exhaust piping well beyond the roof and use a gradual "U" bend at the end to direct the exhaust outlet downward which will keep rain, snow, etc., out of the pipe. The outlet of the pipe should be far enough away from the roof to prevent ignition of the roof material from hot exhaust.

WALL THIMBLES

Approved wall thimbles should be constructed so that they extend at least (6) inches both ways from the surface of the wall. Wall thimbles have ventilation holes on one end which should be oriented to the inside of the building.

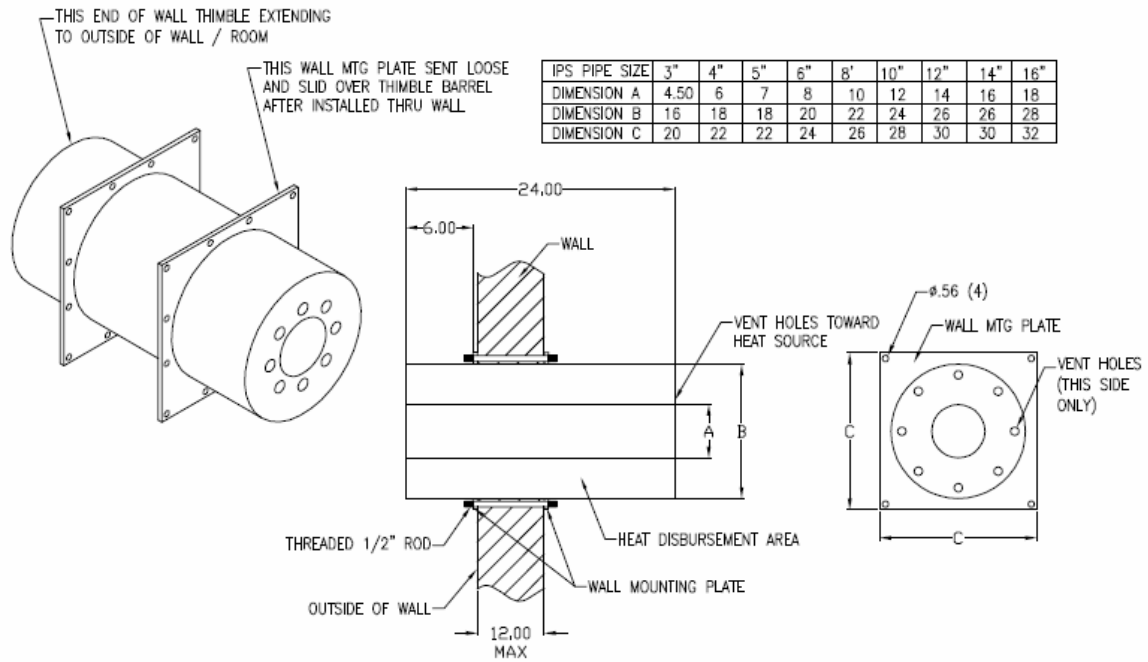

Figure 6-3: Wall thimble installation

TYPE OF FITTINGS (In Inches)	1-1/2	2	2-1/2	3	3-1/2	4	5	6	8	10	12
Standard Elbow (In Feet)	4.4	5.3	6.4	8.1	9.6	11	14	16	21	26	32
Long Rad. Elbow (In Feet)	2.8	3.5	4.2	5.2	6	7	9	11	14	17	20
Med. Rad. Elbow (In Feet)	3.6	4.6	5.4	6.8	8	9	12	14	18	22	26
Standard Tee (In Feet)	9.3	13	14	17	19	22	27	18	44	56	67

Table 6-1: Equivalent lengths of pipe fittings

7

Fuel System

GENERAL

The fuel system must be installed properly to assure availability of fuel for starting and continuous running throughout the emergency. Before connecting the fuel lines to the engine, ensure that fuel connections are free from dirt, grease, water and other contaminants that could damage the engine.

The components comprising a fuel system will differ according to the generator set location, type of fuel and anticipated time of operation desired.

DIESEL APPLICATIONS

The following basic components comprise a representative diesel fuel system:

1. Main Fuel Tank Incorporating:
 - a. Fill Line
 - b. Vent Line
 - c. Supply Line with Foot Valve
 - d. Return Line
2. Day Tank (if required)
 - a. Pump Control Switch
3. Electric Fuel Transfer Pump (if necessary)

MAIN FUEL TANK

The best location for the main fuel tank is as close to the engine as possible. If building codes and insurance regulations permit, the tank could be located in the same room as the generator set, or in an adjoining room. If this is not possible, the tank should be located in a convenient location compliant with local, regional and national codes.

The fuel level in the main tank should be level with the engine's fuel transfer pump inlet. If located in the room, the tank should be on the same general level as the engine's fuel injection pump but lower than the injectors. When the tank must be placed higher or lower than this, it often requires the usage of priming or float tanks. When the main tank can be located close to the set and where the vertical lift is 5 feet or less, the fuel injection pump may be capable of supplying sufficient fuel. If the horizontal run is too great, or the vertical height exceeds 5 feet, a transfer pump is required. As a general rule, when static head and dynamic suction (horizontal head) exceed 6 inches hg (column mercury) an auxiliary pump and tank are required. A float tank or transfer tank is required with the auxiliary pump. The auxiliary pump should be of the positive displacement type, operated electrically from the load side of the transfer switch.

All tanks must be vented to a safe area in the event of an overflow and to allow air and other gases to escape to atmosphere. The vent must, however, prevent dust, dirt and moisture from entering the tank. Return lines are required. Keep the return space at least 12 inches away

from the pick-up or fuel supply in the day tank. If this is not done, air bubbles could be entrapped in the fuel and cause erratic operation. At least 5% of capacity should be allowed in a diesel main tank for expansion of the fuel. If the main tank is to be located overhead, an auxiliary fuel shut-off solenoid should be used.

The capacity of the fuel tank will be determined by the fuel consumption of the unit and the continuous operating time necessary. Minimum fuel supply must be sufficient to allow the set to operate for the prescribed number of hours. Before installing a fuel tank, review all local code requirements governing fuel tanks.

The number of lines connected to an underground fuel tank, whose depth of burial exceeds the below grade depth of the electric generating unit, will vary as a function of day tank positioning with regard to the engine and the number of ancillary devices utilized. However, all underground tanks must have the following:

- A vent line terminating above ground level in a screened or hooded type vent cap with unrestricted opening to atmosphere and a safe area, in the event of an overflow, that meets all necessary codes.
- A fuel fill line terminating above grade level, and fitted with an appropriate cap, and terminating in a fuel filler box with an appropriate cap plainly marked for the fuel utilized.
- A fuel supply line connected from the tank to an electric fuel transfer pump is needed when the fuel tank is located below the fuel lifting capacity of the set. The end of the fuel supply line within the tank must be fitted with a foot valve (permits flow in one direction only) to prevent loss of transfer pump prime when the transfer pump is not in operation.
- The day tank should be positioned so that the bottom of the day tank is above the level of the engine fuel filters in order to provide a positive head of pressure for the fuel injection pump. The mounting of the day tank in this manner will prevent loss of prime to the unit fuel injection pump and is recommended particularly in applications where the unit is utilized as a standby power source. In all applications, the return lines should returned to the main tank.

Local and national regulations governing fuel tank location must be checked before planning the installation. Fuel tanks must be adequately vented to prevent pressurization due to fuel expansion when heated.

CAUTION

The fuel system needs to be sized to handle the fuel flow required by the engine. Engine fuel flow is greater than engine fuel consumption and varies for different engine models. Engine fuel flow and consumption can be found on the model specification sheets located in the Operation and Maintenance manual.

The fill, supply and return lines as well as all diesel fuel system piping must be constructed of black iron pipe. Do not use galvanized pipe for diesel fuel applications.

CAUTION

Galvanized tanks and piping must not be used since the diesel fuel and the galvanized coating react chemically to produce flaking which quickly clogs filters or causes failure of the fuel pump or injectors. Do not use Teflon tape on fuel fittings as it can clog the fuel injectors.

Cast iron and aluminum fittings and pipe should be avoided since they are porous and can leak fuel. Flexible fuel lines must be used to connect the unit to the fuel supply and return lines. Flexible lines must be of the type approved for diesel fuels.

WARNING!

Leaky fuel lines and fuel connections can introduce the possibility of explosion and fire, which can result in injury or death. Ensure fuel lines are properly connected and flexible lines are used between the engine and supply and return lines.

Fuel filters and drains must be located in easily accessible areas to promote regular and frequent service. Cleanliness of the fuel is critical for diesel engines that have easily damaged or clogged precision fuel injectors and pumps.

DAY TANK

The day tank provides a ready supply of fuel at the injector pump. Day tanks are used when the engine pump does not have the necessary lift to draw fuel from the main tank. If the main tank is above the level of the injectors, the day tank is used to remove the fuel head pressure that would otherwise be placed on the engine fuel system components.

A slight head of fuel can cause leakage through the injectors and result in hydraulic lock problems such as filling of the engine cylinder with liquid fuel. The injector return line must always be at or below the level of the fitting on the engine. The line must drain toward the day tank.

FUEL OIL TRANSFER PUMP

The fuel oil transfer pump (auxiliary pump) is used to supply fuel from the main tank to the day tank.

Single phase 120 VAC or 240 VAC, the AC power supply for the transfer pump should be taken from the load side of the transfer switch. The pump will operate when its circuit is closed by the action of the level switch.

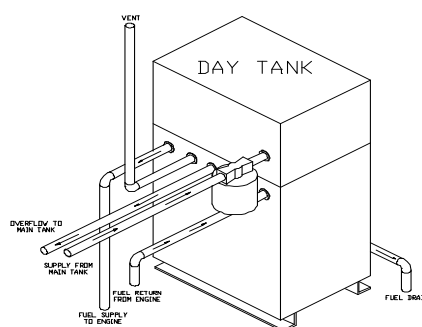

Figure 7-1: Fuel day tank

Fuel is then drawn from the main tank through a foot valve and is pumped into the day tank. Operation continues until the fuel level in the day tank rises causing the float to rise, opening the float switch and disconnecting the pump motor.

DIESEL FUEL RECOMMENDATIONS

MTU Onsite Energy recommends the use of #2-D diesel fuel.

#2-D Diesel Fuel:

A good quality 40 cetane (min) #2-D diesel fuel is best for most MTU Onsite Energy diesel generator set installations. This must be a distillate fuel which meets the requirements for #2-D in the ASTM diesel fuel classification D-975-60T. Most major brands of fuel oils conform to ASTM specifications.

#1-D Diesel Fuel:

A #1-D grade 40 cetane (min) diesel fuel may be best if operating at altitudes above 5000 feet or in cold weather (below 40° F) conditions. Kerosene is included in the #1-D class of fuel. This fuel has a lower flash point (more volatile) and is of lower viscosity (flows more freely) than #2-D.

#2 Domestic Type (Furnace) Oil:

#2 domestic or furnace oil may be used. The #2 domestic fuel should have properties as close as possible to that of #2 diesel fuel. Check ASTM D-396-60T. Particular attention must be given to the sulfur content – this must be less than 1% by weight. High sulfur content can lead to increased engine wear and shorter injector life, especially if intermittent operation or low operating temperatures exist.

#4-D Grade Fuel: (NOT RECOMMENDED)

The high sulfur content plus low cetane rating of this class of fuel makes it unsuitable for diesel generator set use.

GASEOUS FUEL SYSTEMS

System Variations: The gaseous fuel systems used can be grouped in 4 general classifications. The systems are covered in the following sequence:

1. Natural Gas (including manufactured gas)
2. LP Vapor
3. Liquefied Withdrawal
4. Dual Fuel Systems (natural gas and LP gas)
5. Zero Pressure Regulation

1. & 2. NATURAL GAS AND VAPOR PROPANE (FIGURE 7-2A):

Natural, manufactured, sewage and most LP Vapor gas systems are vapor fuels as supplied by the utilities. These fuel system components are used in a similar manner. When the heating content of the fuel falls below 1000 BTU per cubic foot, as it does with manufactured sewage and some natural gas fuels, the set will have to be derated. Check with the factory for application details. The gas distribution companies will provide piping from the main transmission line to the building. The primary regulator should be furnished by the utility company. It is the responsibility of the utility company to ensure that sufficient pressure is present at all times to operate the primary regulator. Installation, repair and alteration to gas piping should be undertaken only by the utility company or personnel authorized by them. Piping should be rigidly mounted but protected against damage from vibration. Only UL or AGA approved flexible connection should be used.

3. LIQUID WITHDRAWAL

Most LPG systems are operated from vapor. The main tank is sized to vaporize the fuel volume needed for ambient temperature of the installation. Sizing the LPG tank must be the responsibility of the fuel supplier. Give the fuel supplier the fuel volume required.

Vaporizers: Vaporizers are devices used exclusively with LPG systems. LPG in liquid form is introduced under tank pressure into the vaporizer which uses engine coolant heat to convert the liquid into a vapor state. Vaporizers may be referred to as converters; both names describe its function. There are several types of vaporizers. One type is strictly a vaporizer and must be used in conjunction with other pressure regulators. This type of vaporizer may be required if tank size is limited; low ambient temperatures or high fuel volume are conditions affecting the installation. The type classified as vaporizer-regulators provide vaporization plus primary and secondary regulation of gas pressure.

Fire regulations in most localities prohibit liquid LP high-pressure fuel lines inside a building or enclosure. This automatically precludes high-pressure equipment on or near an engine installed inside a building. Under such regulations, the coolant lines can be extended and the vaporizer mounted outside the structure.

Gas at permissible pressure (usually about 20 psi maximum) is allowed inside the building. The vaporizer must be mounted below the level of the engine water pump and within 25 feet of the engine. If freezing temperatures are common, don't overlook the fact that water inside the vaporizer could freeze unless antifreeze is added to the system.

4. DUAL FUEL SYSTEMS (NATURAL OR LP VAPOR)

In many applications, natural gas is the main fuel and LPG is used as the emergency fuel when natural gas is not available. The dual fuel system (in common use) offers automatic changeover from one fuel to the other.

During operation on natural gas, pressure existing in the common line to the carburetor closes off the LP Vapor regulator. Cutting off the natural gas operates a pressure switch in the line which automatically opens the LP Vapor solenoid and closes the natural gas solenoid.

5. ZERO PRESSURE REGULATION

The Zero Pressure Regulator System works on Zero Pressure air and Zero Pressure gas, the engine vacuum is what mixes the fuel and air through the mixer on the carb.

The system still requires 7 to 11" of water column (4 to 6 ounces) on either Natural Gas or LP Vapor.

The flow control valve is left with the tower in the upright position on either fuel and with the spring left in. The Zero Pressure System only requires the installer to give the correct pressure and volume to the system. NOTE: A dog tag on the system shows the fuel consumption and pressures required for each system.

Gas Piping: Piping must never be used to ground electrical apparatus. Piping must be rigidly mounted but protected against vibration. Where flexible connections are required, use only approved connections. A flexible section should be used between the point where the gas leaves the rigid fuel line and enters the engine. Only connections capped off by a temporary plastic plug are intended to be connected to by the end user.

All gas lines and piping should be of black iron. Joints and connections must be sealed. The pipe should be of sufficient size to maintain the proper pressure level when operating at full load. In addition to the actual fuel consumption, the following factors must be considered:

- Pressure loss due to number of fittings
- Specific gravity of gas
- Pressure loss due to length of piping

At the end of the chapter is a list of steps to follow when calculating pipe capacities for gas flow rates.

This procedure is based on a pressure drop of 0.5" H₂O which allows for a normal amount of restriction from fittings.

Table 7-1, Gaseous Fuel Pipe Capacity, lists the capacity of various sizes and lengths of pipe. The capacity (in cubic feet per hour) is calculated using the specific gravity of 0.6 as base. A pressure drop of 0.5" (water column) is used to account for a nominal number of fittings and metering equipment in this table.

Main Components: Solenoid valves used in a gaseous fuel system are designed to close and stop fuel the instant the engine stops. They should not be relied upon to completely seal the

fuel system. A ruptured diaphragm or a piece of grit could prevent the valves from sealing resulting in gas continuing to flow through the carburetor into the engine and out into the surrounding air. Some gaseous fuels are heavier than air and tend to settle in low areas. This could present a serious hazard, especially in enclosed applications. Safeguards against this should be incorporated in each system.

The common components of a gas system are as follows:

Primary regulator: This regulator is used to provide pressure regulation of the gas from the high-pressure supply line or with LPG with the supply tank.

The primary regulator reduces line pressures to allowable inlet pressures for the secondary regulator. This regulator is supplied by the utility or fuel company.

Secondary regulator: The low-pressure type regulator admits fuel to the engine in response to engine demand similar to the float valve in a gasoline carburetor. The secondary regulator is not supplied and must be supplied by the purchaser. Natural gas and LPG vapor withdrawal inlet pressures must be from 4 to 6 ounces per square inch.

PRESSURE REDUCING VALVE

The pressure-reducing valve regulates the volume of fuel to the carburetor. The volume is proportional to the load on the engine.

This device is factory mounted for LP gas vapor withdrawal fuel systems, the valve is inverted and the internal spring removed. Consult factory for drawings showing modifications for propane fuel systems.

Fuel shut-off solenoid: This device automatically shuts off the fuel supply when the engine stops. All MTU Onsite Energy automatic fuel shut-off valves are electrically activated solenoids that seal off the fuel the instant the ignition switch is turned off.

Carburetor: Gas carburetors operate on gaseous fuels only.

*NFPA 37 requires the electric solenoid to be placed ahead of any flexible connector. This solenoid is not supplied by MTU Onsite Energy.

DETERMINING PIPE SIZE FOR GASEOUS FUEL SYSTEMS

1. Obtain the fuel consumption in cubic feet per hour at 100% load from the engine generator model specification sheet for the type of fuel used.
2. Refer to the correction chart below, and select the correction factor for the type of fuel used.

Fuel Specific Gravity	Fuel	Correction Factor
.65	Natural Gas	.962
1.00	Air	.775
1.50	Propane	.633
2.10	Butane	.535

3. Divide the fuel consumption from step 1 by the correction factor to obtain adjusted flow rate.
4. Determine length of pipe between the fuel source and generator set.
5. From table 6.1, choose the column of the nearest pipe length.
6. Move down the column until the figure equal to or greater than the adjusted flow rate obtained in step 3 is encountered.
7. Move horizontally to the left column to determine the correct pipe size.

Iron Pipe Size (in.) Nominal	Length of Pipe (ft.)													
	10	20	30	40	50	60	70	80	90	100	125	150	175	200
1/4	43	29	24	20	18	16	15	14	13	12	11	10	9	8
3/8	95	65	52	45	40	36	33	31	29	27	24	22	20	19
1/2	175	120	97	82	73	66	61	57	53	50	44	40	37	35
3/4	360	250	200	170	151	138	125	118	110	103	93	84	77	72
1	680	465	375	320	285	260	240	220	205	195	175	160	145	135
1-1/4	1400	950	770	660	580	490	460	460	430	400	360	325	300	280
1-1/2	2100	1460	1180	990	900	810	750	690	650	620	550	500	460	430
2	3950	2750	2200	1900	1680	1520	1400	1300	1220	1150	1020	950	850	800
2-1/2	6300	4350	3520	3000	2650	2400	2250	2050	1950	1850	1650	1500	1370	1280
3	11000	7700	6250	5300	4750	4300	3900	3700	3450	3250	2950	2650	2450	2280
4	23000	15800	12800	10900	9700	8800	8100	7500	7200	6700	6000	5500	5000	4600

Table 7-1: Gaseous Fuel Pipe Capacity

EXAMPLE

- Engine – generator set operating with a fuel consumption of 700 cubic feet per hour and at a distance of 50 feet from the fuel supply
- Fuel used is propane and has a specific gravity of 1.5
- Dividing the flow rate of 700 CFH by the correction factor of 0.633 for propane gives the adjusted capacity of 1105 CFH
- Reading down the 50-foot pipe length column in table 6.1 until a figure equal to or greater than 1106 is encountered, we get a figure of 1680
- Reading directly across to the left column gives the required pipe size of 2 inches

8

Electrical Requirements

GENERAL

The electrical system consists of the AC power supplied to the generator and the DC starting and control circuitry. These circuits must be enclosed in separate conduits.

BATTERIES

The batteries need to be provided with enough capacity to provide the cranking motor current specified on the unit specification sheet. The recommended batteries are lead-acid or nickel cadmium. They can be shipped wet or dry. If shipped dry, they can be stored indefinitely and when ready to use filled with electrolyte (acid) with a specific gravity of 1.250 to 1.265. It is recommended that batteries be placed on trickle charge for 12 hours after electrolyte is added.

Batteries should be located as close as possible to the generator set to eliminate line losses.

Nickel cadmium batteries are shipped wet. It is advisable that batteries be placed on trickle charge for 12 hours when received.

Coat battery terminal connections with grease to prevent corrosion. Check the electrolyte level periodically. Make certain all vent caps are in place and unobstructed.

BATTERY RACKS AND CABLES

Where the battery installation requires remote battery location, the correct cross sectional area of battery cables is of importance in minimizing line drop. Battery racks or boxes are supplied by MTU Onsite Energy for lead-acid batteries.

AC POWER OUTPUT WIRING

All wiring must be in accordance with applicable electrical codes. Wires must be of adequate size, properly insulated and supported in an approved manner. Wires should not be placed where they may interfere with plant operation. Figure 8-1 illustrates the various generator connections for MTU Onsite Energy generators.

WARNING

Accidental contact with electrical equipment can cause severe injury and death if the equipment is not properly grounded. Ensure that all equipment is properly grounded.

AUTOMATIC TRANSFER SWITCH

Installing an automatic transfer switch is primarily an electrical operation and, therefore, should be handled by a licensed electrician. Instructions and detailed wiring diagrams will accompany the switch.

The transfer switch is designed to be mounted on a wall or other vertical surface free from vibration. The switch should be at the electrical service entrance and yet within 100 feet with No. 12AWG wire from the generator set control cabinet.

REMOTE/AUDIBLE ALARM

An external fault indicator or audible alarm can be wired to the generator set. Make certain external fault indicator or audible alarm is rated for 2 amperes maximum and 12 or 24 VDC depending on the DC voltage of the system. The indicator will become illuminated or the alarm will sound when an overcrank, low lube pressure, high coolant temperature or overspeed condition occurs.

ACCESSORY WIRING

When motor operated louvers are required for a generator set installation, the louver motors must be wired to operate whenever the engine generator set runs, during emergency conditions, normal periodic exercising, or for maintenance.

MTU Onsite Energy suggests the louver motors be wired to a distribution panel on the load side of the automatic transfer switch. The louver motor control circuit is wired to “energized to run” contacts in the generator set control panel.

TWELVE LEAD PARALLEL DELTA

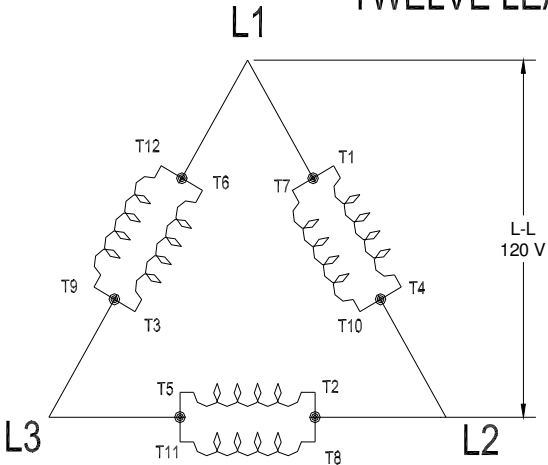

Delta connection with 12 lead generators only.
 Voltages: 60 Hz 120v TO 139v
 50 Hz 100v TO 120v

VOLTAGE	CONNECT	L1	L2	L3
120 DELTA	T1, T7, T6, T12 T2, T8, T4, T10	T1	T2	T3
	T3, T5, T9, T11			

TWELVE LEAD ZIG-ZAG OR OPEN DELTA

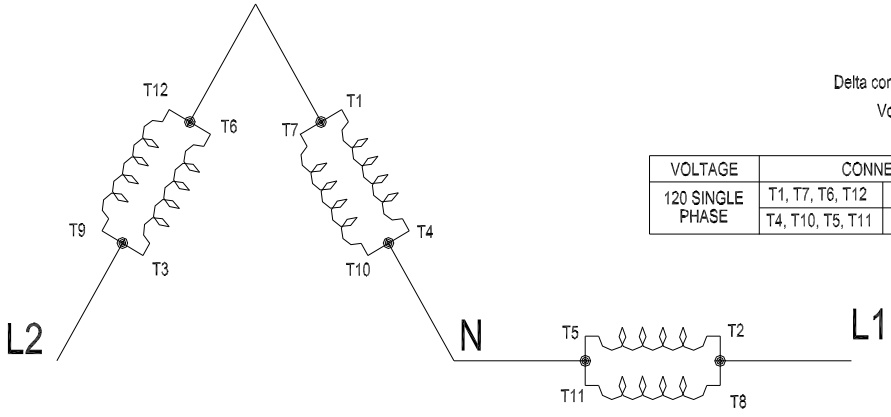

Delta connection with 12 lead generators only.
 Voltages: 60 Hz 120/240v single phase
 50 Hz 110/220v single phase

VOLTAGE	CONNECT	L1	L2
120 SINGLE PHASE	T1, T7, T6, T12 T3, T9	T2, T8	T3, T9
	T4, T10, T5, T11	T2, T8	

TWELVE LEAD SERIES WYE

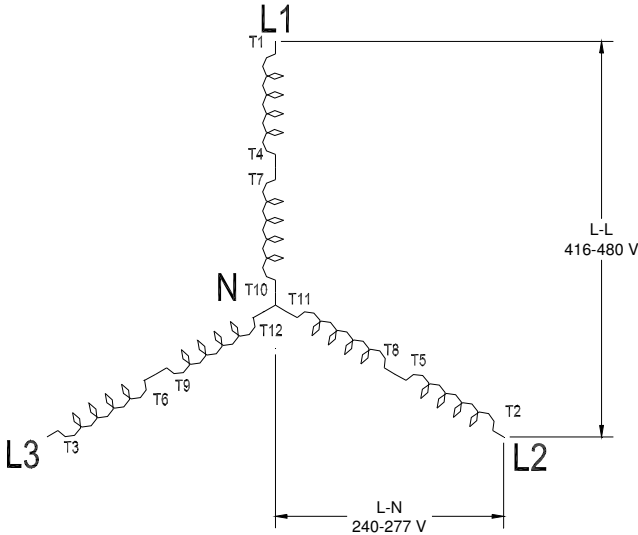

Voltages: 60 Hz 240/416v TO 277/480v
50 Hz 220/380v TO 240/416v

VOLTAGE	CONNECT			L1	L2	L3	NEUTRAL
	T4, T7	T5, T8	T6, T9				
480-416 WYE	T10, T11, T12			T1	T2	T3	T10, T11, T12
	T4, T7	T5, T8	T6, T9				

TEN LEAD SERIES WYE

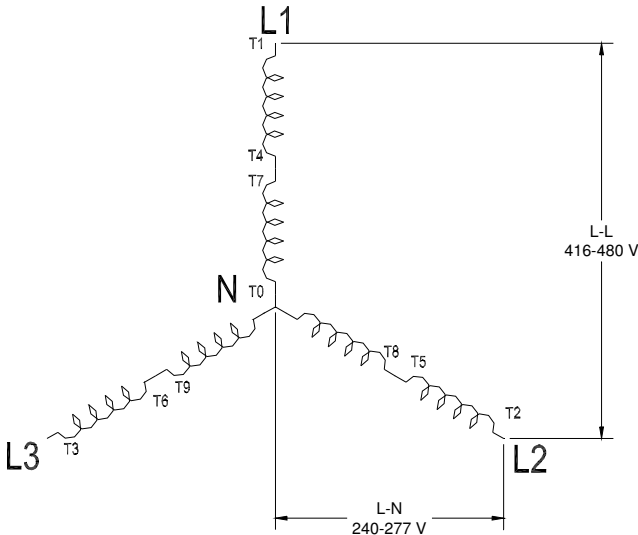

Voltages: 60 Hz 240/416v TO 277/480v
50 Hz 220/380v TO 240/416v

VOLTAGE	CONNECT			L1	L2	L3	NEUTRAL
	T4, T7	T5, T8	T6, T9				
480-416 WYE	T0, T10, T11, T12			T1	T2	T3	T0
	T4, T7	T5, T8	T6, T9				

TWELVE LEAD PARALLEL WYE

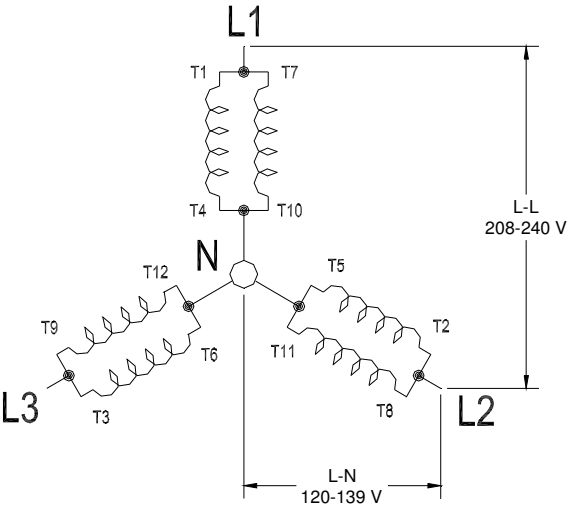

Voltages: 60 Hz 120/208v TO 139/240v
50 Hz 110/190v TO 120/208v

VOLTAGE	CONNECT			L1	L2	L3	NEUTRAL			
	240-208 WYE	T10, T11, T12	T4, T5, T6	T1, T7	T2, T8	T3, T9	T1	T2	T3	T10, T11, T12

TEN LEAD PARALLEL WYE

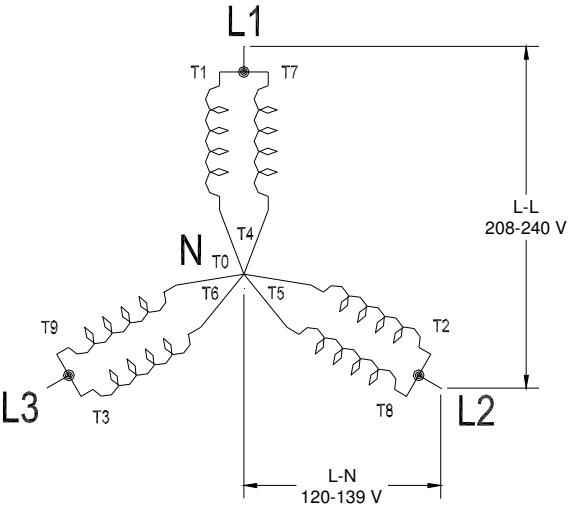

Voltages: 60 Hz 120/208v TO 139/240v
50 Hz 110/190v TO 120/208v

VOLTAGE	CONNECT			L1	L2	L3	NEUTRAL			
	240-208 WYE	T4, T5, T6, T10			T1, T7	T2, T8	T3, T9	T1	T2	T3

TWELVE LEAD SERIES DELTA

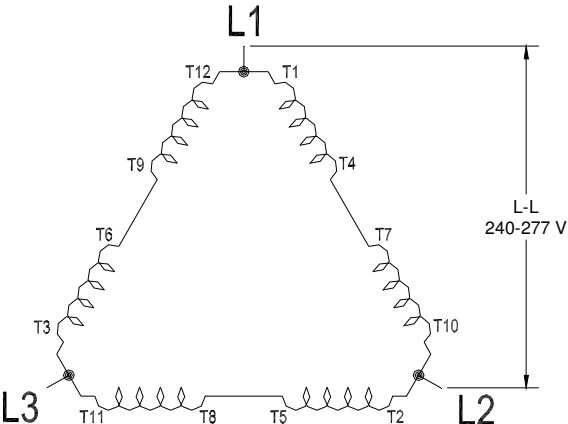

Voltages: 60 Hz 120/240v TO 138/277v
50 Hz 110/220v TO 120/240v

VOLTAGE	CONNECT			L1	L2	L3			
	240-277 DELTA	T4, T7	T5, T8	T6, T9	T1, T12	T2, T10	T3, T11	T1	T2

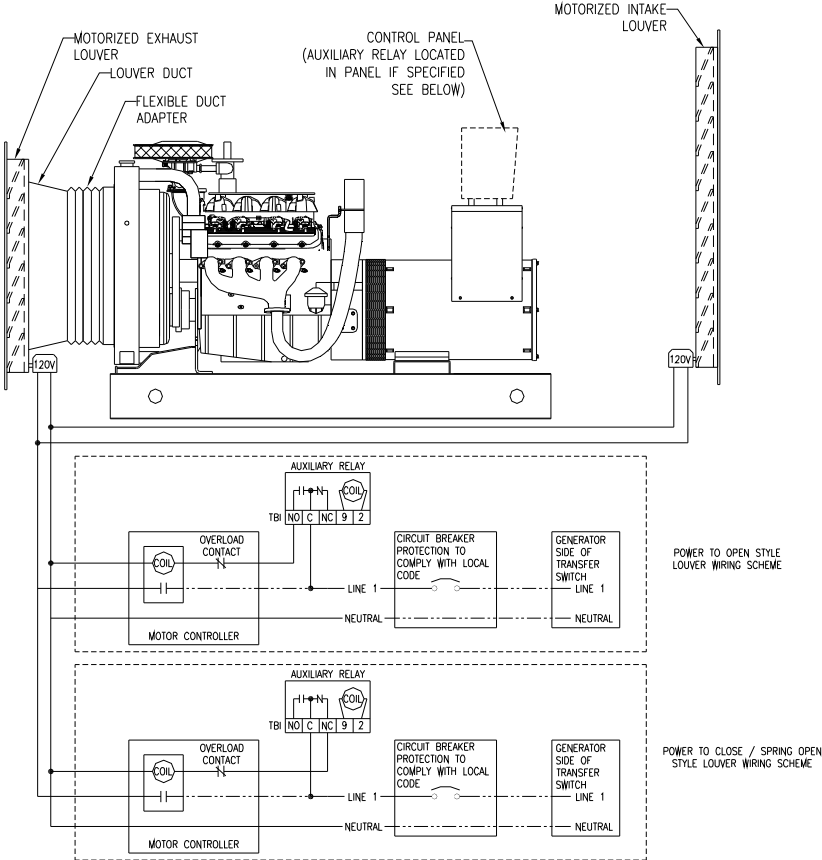

Figure 8-1: Suggested motorized louver wiring

As an alternate-wiring scheme, the louver motor may be wired directly to the generator output leads, prior to the mainline circuit breaker. The installation contractor must add any necessary wiring devices and circuit protection to comply with the local electrical code requirements.

There are many other wiring schemes which may be used to safely wire the louver motors and control circuits to ensure the louvers will open when the engine generator set runs. If there are any questions, consult your generator set supplier.

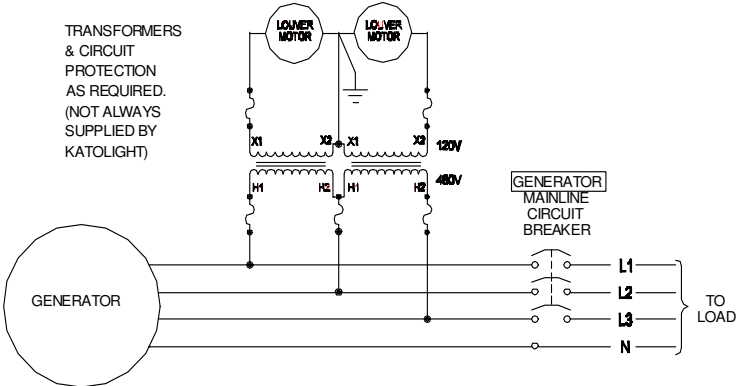

Figure 8-2: Optional motorized louver wiring

9

Service

Install the generator set in an area that can be quickly reached for repair in case of malfunction. Service entrances should be large enough to permit service of components such as engine, radiator or generator in the event major overhaul or replacement is needed.

The location for items requiring service varies from model to model. All service items should be known and considered when planning the installation. An item requiring routine attention must, of course, be made more accessible.

In general, the following service points should be accessible:

- Air Cleaner
- Primary Fuel Filter
- Secondary Fuel Filter
- Lube Oil Dip Stick
- Oil Filter
- Starting Battery
- Starter
- Battery Charger & Voltage Regulator
- Generator & Control Systems

If your generator set requires service or repairs, simply contact an authorized MTU Onsite Energy dealer for assistance. Service technicians are factory-trained and are capable of handling all of your service needs.

When contacting a MTU Onsite Energy Authorized Dealer, always supply the complete model number and serial number of your unit, which are located on your generator set nameplate.

To locate the MTU Onsite Energy Authorized Dealer nearest you, call 800-325-5450.

NOTE

For standby units, it is important that servicing is performed on a calendar basis. Failure to do this may result in the generator set not starting or operating properly when the unit is most needed. Consult your Operation and Instruction Manual provided with the generator set for servicing information.

10

Installation Checklist

Prior to initial start-up, refer to the following installation checklist to ensure that the generator set is installed properly.

CHECK	OK	CHECK	OK
1. Adequate clearance on all sides.		19. Exhaust nipple installed on manifold below flexible exhaust connection (condensate trap).	
2. Doors on unit must be in alignment.		20. Exhaust piping sloped away from engine.	
3. Remove engine locks and vibration isolator blocks.		21. Condensate trap or drain installed.	
4. Confirm proper alignment of angular displacement, radial displacement and axial displacement (applicable only to two-bearing generators only).		22. Muffler exhaust flow in right direction.	
5. Adequate incoming air flow.		23. Exhaust line free of excessive elbows and restrictions.	
6. Adequate outgoing air flow.		24. Exhaust line shielded/protected.	
7. Radiator duct flange connected.		25. Battery in cool location.	
8. Antifreeze required/installed.		26. Battery properly charged.	
9. Water heater properly connected and of proper voltage.		27. Battery of proper size and voltage.	
10. Proper size fuel line and connectors.		28. Battery cables correct size.	
11. Fuel lines protected.		29. Battery charger operating.	
12. Fuel pump lift adequate.		30. Generator properly connected.	
13. Flexible fuel connectors.		31. All controller contacts clean.	
14. Fuel return line.		32. Transfer switch operating correctly.	
15. Gas pressure acceptable.		33. Binding posts tight (all connections).	
16. Solenoid shut-off valve installed (gas).		34. Operator has instruction manual.	
17. Proper size exhaust line.		35. Maintenance schedule posted.	
18. Flexible exhaust connection installed.		36. No loose parts, belts, bolts, nuts, etc.	

11

Start-Up Request Form

To provide an authorized factory start-up at the lowest possible prices, we must request that the following checklist and tasks be completed prior to a MTU Onsite Energy representative's arrival at the installation site to perform the start-up.

Unit Serial Number: _____ **Contact Name:** _____

Company Name: _____ **Title:** _____

Please attach a map or directions to the site. **Phone Number:** (_____) _____

- Unit set in place on vibration pads with floor anchor/studs to prevent movement.
- Doors on unit in alignment.
- Radiator ducted to properly sized air discharge louvers.
- Unit full of oil and water/anti-freeze mix.
- Battery filled with acid and fully charged.
- Battery charger mounted with AC and DC wired, if not supplied mounted by the factory.
- All AC and DC electrical connections made.
- Engine heater wired to normal AC power supply.
- Fuel inlet and return lines run between the unit and fuel storage system, system filled and primed to the engine with proper fuel.
- Exhaust system in place and supported so that the exhaust manifold does not carry weight of exhaust system.
- Air inlet louver motor wired to an emergency generator source point to open upon the start of an engine generator set.
- Generator room cleaned of construction debris including excess nails, bolts, nuts, panel knockouts, etc. It is very important that the radiator fan area is checked for debris, as damage to the equipment and personal injury can occur if loose items come in contact with the fan when the unit is initially started.

Consult your Installation Guide on any questions.

If, upon arrival at the installation site, our representative cannot perform the start-up as a result of defective MTU Onsite Energy equipment, the problems will be resolved and we will reschedule another start-up date at the earliest possible date at no additional charge.

If the start-up cannot be performed due to an incomplete installation or for reasons beyond MTU Onsite Energy's control, you may incur an additional start-up charge at a later date.

Signature: _____ **Date:** _____

Operating Procedures

CAUTION

The high engine temperature shutdown system will not operate if the coolant level is too low. The high engine temperature sensor monitors coolant temperature. Loss of coolant will prevent sensor operation and allow the engine to overheat causing severe damage to the engine. Therefore, maintain adequate coolant level for proper operation of the high engine temperature shutdown system.

Low Coolant Level Shutdown: A submerged sensor in the top portion of the radiator shuts down the engine and lights the Hi Engine Temp fault lamp when the coolant level falls below the level of the sensor. Top off coolant frequently.

Prior to starting or testing the generator set, refer to the engine manual for maintenance checkpoints. Items such as oil level, coolant level, belt tension, battery electrolyte level, wire connections, and air filter are some of those that should be checked frequently.

CAUTION

Stop engine before filling fuel tank. Never fill tank when engine is hot.

STARTING PROCEDURE

The following sections cover the 3 systems used to start the generator set. See Pages 8 – 14 for panel description and illustrations.

Starting at Control Panel

Move the RUN/OFF/AUTO switch on the control panel to the RUN position. This will activate the engine control system and the starting system. The starter will begin cranking and after a few seconds the engine should start. The starter will disconnect when the engine reaches a speed of 500-750 RPM. If the engine does not start, the starter will disengage at the end of the cranking cycle. MTU Onsite Energy generator sets with the cycle cranking will crank for 10 seconds and then rest for 10 seconds until 5 cycles have been completed, then lock out on overcrank (fail to start). To clear an overcrank fault, place the RUN/OFF/AUTO switch in the OFF position. Wait 2 minutes for the starter motor to cool and then repeat the starting procedure. If the engine does not run after a second attempt at starting, refer to the **Troubleshooting** section.

Automatic Starting

Place the RUN/OFF/AUTO switch on the generator set control panel in the AUTO position if an automatic transfer switch is used. This allows the transfer switch to start the generator set if a power outage occurs and stop it when the power returns. **Be aware the genset could start at any time in the “AUTO” mode. Keep clear of**

all moving parts and be sure to turn switch to “OFF” position before servicing and disconnect the negative battery cable after disconnecting the battery charger circuit.

STOPPING PROCEDURE

Before Stopping

Run the generator set at no load for 3 to 5 minutes before stopping. This allows the lubricating oil and engine coolant to carry heat away from the combustion chamber and bearings.

To Stop

If the set was started at the set control panel or at a remote control panel, move the RUN/OFF/AUTO switch or remote starting switch to the OFF position. If an automatic transfer switch started the set, the set will automatically stop after the normal power source returns and time delays have been satisfied.

BREAK-IN

Drain and replace the crankcase oil and oil filter(s) after the first 30 to 50 hours of operation on new generator sets. Refer to the **MAINTENANCE** section of the Engine manual for the recommended procedures. It is recommended to achieve the break in during the first 2 months after installation is completed. This will familiarize the operator with the system.

NO-LOAD OPERATION

Periods of no load operation should be held to minimum. If it is necessary to keep the engine running for long periods of time when no electric output is required, best engine performance will be obtained by connecting a “dummy” electrical load. Such a load could consist of Load Banks.

EXERCISE PERIOD

Generator sets on continuous standby must be able to go from a cold start to being fully operational in a matter of seconds. This can impose a severe burden on engine parts. Regular exercising keeps engine parts lubricated, prevents oxidation of electrical contacts and in general helps provide reliable engine starting. Exercise the generator set at least once a week for a minimum of 30 minutes with load so the engine reaches normal operating temperatures. The Automatic Transfer switch has an optional exerciser that can be preset to provide regular exercise periods. Typically the exerciser can be set for time of start, length of run, and day of week.

LOW OPERATING TEMPERATURES

Use a coolant heater if a separate source of power is available. The optional heater will help provide reliable starting under adverse weather conditions.

Be sure the voltage of the separate power source is correct for the heater element rating. The heater should be in use year round. A heater is required on all automatic systems to prevent engine damage due to short warm up cycles.

AUTOMATIC TRANSFER SWITCH

DANGER

HAZARDOUS VOLTAGE will cause severe injury or death. Turn OFF all power before installation, adjustment or removal of transfer switch or any of its components.

EQUIPMENT INSPECTION

Immediately inspect the transfer switch when received to detect any damage, which may have occurred during transit. If damage is found or suspected, file claims as soon as possible with the carrier and notify the nearest MTU Onsite Energy representative. The switch cabinet should be opened at inspection to check for internal freight damage, even if the box and cabinet enclosure appear undamaged.

FINAL EQUIPMENT INSPECTION

Prior to energizing the transfer switch:

- Remove any debris incurred due to shipment or installation. DO NOT use a blower since debris may become lodged in the electrical and mechanical components and cause damage. Use of a vacuum is recommended.
- Verify that all cabled connections are correct. Verify phase rotation and position of the high leg at both sources on the delta system.
- Check engine start connections and verify the correct connection of all control wires.
- Check settings of all timers and adjust as necessary. Also adjust any optional accessories as required.
- Check the integrity of power connections by verifying actual lug torque values as specified in the ATS manual.
- Make sure that all covers and barriers are installed and properly fastened.

FUNCTIONAL TEST

Since there are various transfer switch designs available, please refer to the operator manual provided with the transfer switch for specific details.

The functional testing of the transfer switch consists of electrical tests described in this section. Before proceeding, refer to the information package supplied with the transfer switch. Read and understand all instructions and review the operation of all accessories provided.

Before starting the operation test, check the equipment-rating nameplate on the transfer switch to **verify the correct system voltage**.

To begin the test, close the Normal source circuit breaker. The micro-controller will illuminate the Normal Available LED if proper voltage is sensed. Verify the phase-to-phase voltages at the Normal line terminals.

Next, close the Emergency source breaker and start the engine generator. The Emergency Available LED indicator will illuminate when preset voltage and frequency levels are achieved. Check the phase-to-phase voltages at the Emergency line terminals. Also, verify that the phase rotation of the Emergency source is the same as the phase rotation of the Normal source.

After the sources have been verified, shut down the engine generator, and put the starting control in the automatic position. Complete the visual inspection of the transfer switch, and close and lock the cabinet door.

Initiate the electrical transfer test by activating the test switch. **Hold the test switch until transfer to Emergency is accomplished.** After the engine start time delay, the micro-controller will send an engine start signal and sensing will determine when the auxiliary source reaches preset levels. The switch will transfer to the Emergency source after the time delay of the transfer to the Emergency timer.

Deactivating the test switch will start retransfer to the Normal source. The switch will retransfer to the Normal source after the time delay of the retransfer to Normal timer. The engine over-run timer allows the engine generator to run unloaded for a preset cool-down period.

For complete details of timer and voltage sensing operations, please refer to the Automatic Transfer Switch Operation Manual.

MAINTENANCE AND TESTING

A preventive maintenance program will ensure high reliability and long life for the transfer switch. The preventive maintenance program for the transfer switch should include the following items.

INSPECTION AND CLEANING

DANGER

HAZARDOUS VOLTAGE. De-energize all sources of power before doing any work on the transfer switch. Note: If approved disconnects are not in place contact your Local Electric Utility or a qualified Electrician before proceeding.

The switch should be inspected for any accumulation of dust, dirt, or moisture, and should be cleaned by vacuuming or wiping with a dry cloth or soft brush. **DO NOT** use a blower since debris may become lodged in the electrical and mechanical components and cause damage.

Remove the transfer switch barriers and check the condition of the contacts. Any surface deposits must be removed with a clean cloth (**DO NOT USE EMERY CLOTH OR A FILE**). If the contacts are pitted or worn excessively, they should be replaced. A general inspection of mechanical integrity should be made to include loose, broken or badly worn parts.

SERVICING

All worn or inoperative parts must be replaced using recommended replacement parts. Please refer to the Replacement Parts manual for specific part information and ordering procedures. Please contact your nearest Distributor.

The operating mechanism of the transfer switch is lubricated. The lubricant applied at the factory provides adequate lubrication for the lifetime of the switch. Should debris contaminate the mechanism, clean and apply additional lubricant. (See Automatic Transfer Switch Manual for proper lubricant type).

TESTING

A manual operator handle is provided with the transfer switch for maintenance purposes only. Manual operation of the switch must be checked before it is operated electrically. Both power sources **MUST** be disconnected before manual operation of the switch. Insert the handle and operate the transfer switch between the Normal and Emergency positions. The transfer switch should operate smoothly without binding. Return the switch to the Normal position, remove the handle, and return it to the holder provided.

After completing the inspection, cleaning and servicing of the transfer switch, reinstall the switch cover, and close and lock the cabinet door. Reclose the circuit breakers feeding the utility and generator sources to the switch.

Initiate the electrical transfer test by activating the test switch. Engine start timer will time out and the micro-controller will send an engine start signal. When the transfer to Emergency time has elapsed, the switch will complete its transfer by closing into the Emergency source.

Deactivating the test switch will start retransfer to the Normal source. The switch will complete its retransfer to Normal after the time delay of the retransfer to Normal timer. The engine over-run timer allows the engine generator to run unloaded for a preset cool down period.

GOVERNORS**MECHANICAL GOVERNOR ADJUSTMENTS**

All MTU Onsite Energy gensets are tested at full load prior to shipment and the speed settings are adjusted. The typical settings will vary from 60 – 63 Hz at no load and are set to operate at 60 Hz when loaded to the nameplate rating. If the system load does not reach the nameplate rating the speed can be adjusted down to 60 Hz. Care must be taken to ensure that the MTU Onsite Energy genset operates at no less than 60 Hz when the entire load to be on the unit is applied. See Figures 12-1 and 12-3 to find the typical speed adjust locations.

ELECTRONIC GOVERNOR DIESEL ADJUSTMENTS

Governor Speed Setting (Diesel)

The governed speed set point is increased by clockwise rotation of the Speed adjustment control. Remote speed adjustment can be obtained with an optional Speed Trim Control. See Figure 12-1.

Governor Performance (Diesel)

Once the engine is at operating speed and at no load, the following governor performance adjustments can be made: Rotate the Gain adjustment clockwise until instability develops. Gradually move the adjustment counterclockwise until stability returns. Move the adjustment 1/8 of a turn further counterclockwise to ensure stable performance.

Rotate the Stability adjustment clockwise until instability develops. Gradually move the adjustment counterclockwise until stability returns. Move the adjustment 1/8 of a turn further counterclockwise to ensure stable performance.

Gain and stability adjustment may require minor changes after engine load is applied. Normally, adjustments made at no load achieve satisfactory performance. A strip chart recorder can be used to optimize the adjustments further. If instability cannot be corrected or further performance improvements are required, contact the nearest distributor or Service Center.

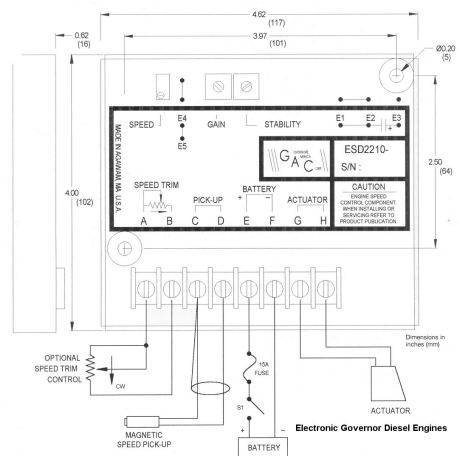

Figure 12-1: Standard GAC Governor Control

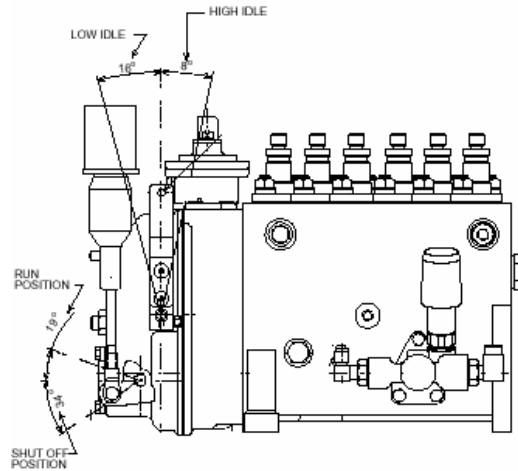

Figure 12-2: Standard Mechanical Governor for Diesel Engines

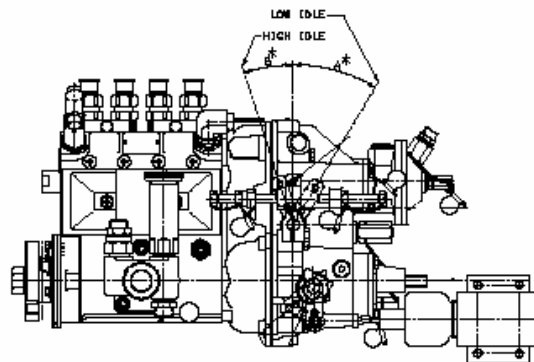

Figure 12-3: Standard Mechanical Governor for Diesel Engines

GAS ENGINE GOVERNOR SYSTEM

The gaseous engines utilize an electronic governor as standard. The governors are microprocessor controlled and have no operator accessible adjustments. The speed is factory set to operate at 60.1 hertz.

13

Troubleshooting

The generator set has a number of sensor units that continuously monitor the engine for abnormal conditions such as low oil pressure or high coolant temperature. If an abnormal condition does occur, the engine monitor will activate a fault lamp and may also stop the engine depending on the condition. If the generator set does shut down, the operator may be able to restart the set after making certain adjustments or corrections. This section describes the operation of the fault condition system and suggested troubleshooting procedures for the operator.

Depending on the model of the generator set, set points, pre-alarms and alarms may vary for oil pressure and coolant temperature. **Note:** These are generator control set points and **not** engine control set points.

Please consult your distributor for exact set point, pre-alarm and alarm values for your specific generator set.

SAFETY CONSIDERATIONS

High voltages are present within the control panel and generator outlet box when the generator is running.

WARNING

Contacting high voltage components can cause serious personal injury or death. Keep control and outlet box covers in place during troubleshooting.

Generator set installations are normally designed for automatic starting or remote starting. When troubleshooting a set that is shut down make certain the generator set cannot be accidentally restarted. Place the RUN/OFF/AUTO switch in the OFF position and remove the negative battery cable from the starting battery. Also, be sure to turn battery charger disconnect off before servicing battery circuits.

WARNING

Accidental starting of the generator set during troubleshooting can cause severe personal injury or death. Disable the generator set before troubleshooting.

When a fault comes on during operation the type of fault will be displayed on the LCD panel. The control panel will also illuminate an indicator light to correspond with the display. The red LED light will indicate fault (shutdown alarm) or the yellow LED pre-alarm (approaching shut down point).

DISPLAY MODE SWITCH

This switch allows the operator to lock the display by moving the switch upward when in the scroll lock mode, the display will not update. By moving the toggle downward the display will show total run time. When the mode switch is in the mid position (normal mode), the display

will scroll through all parameters. Follow the trouble shooting procedures to locate and correct the problem. For any symptom not listed, contact your Distributor for service. Voltage and amperage may display 3 phases, when operated single phase. The unused positions will display "0".

RESETTING THE CONTROL

Placing the RUN/OFF/AUTO switch in the OFF position and pressing the alarm silence switch can deactivate the external alarm and fault lamp. Locate the problem and make the necessary corrections before restarting the generator set.

MAIN LINE CIRCUIT BREAKER

The generator output mainline circuit breaker is mounted inside the generator outlet box. If the load exceeds the breaker current rating, the breaker will open to prevent the generator from being overloaded. If the circuit breaker trips, locate the source of the overload and correct as required. Manually reset the breaker to reconnect the load to the generator, by pushing the handle down to the open OFF position, then up to the closed ON position.

WARNING

Many troubleshooting procedures present hazards, which can result in severe personal injury or death. Only qualified service personnel with knowledge of fuels, electricity, and machinery hazards should perform service procedures. Review safety precautions on inside cover page.

<p style="text-align: center;">SYMPTOM As Indicated on Display Screen</p>	<p style="text-align: center;">CORRECTIVE ACTION</p>
<p>1. PRE HI ENGINE TEMP. Engine continues to operate.</p>	<p>Indicates engine temperature has risen above the normal operating range, and unit may shut down if corrective action is not taken. If generator is powering non-critical and critical loads and cannot be shut down, use the following:</p> <ul style="list-style-type: none"> • Reduce load, if possible, by turning off non-critical loads. • Check air inlets and outlets and remove any obstructions to airflow. • Open doors or windows in generator area to increase ventilation. <p>If engine can be stopped, follow procedure in Step 2.</p>
<p>2. HI ENGINE TEMP LED. Engine shuts down.</p>	<p>Indicates engine temperature has exceeded allowable limit or coolant level is low (on sets with coolant level sensor). Allow engine to cool down completely before proceeding with the following checks:</p> <ul style="list-style-type: none"> • Check coolant level and replenish if low. Look for possible coolant leakage points and repair if necessary. • Check for obstructions to cooling airflow and correct as necessary. • Check for a slipping fan belt and tighten if loose. • Reset control and restart after locating and correcting problem.
<p>3. PRE LOW OIL PRESSURE. Engine continues to operate.</p>	<p>Indicates engine oil pressure has dropped below the normal operating range and unit may shut down if corrective action is not taken. If generator is powering critical loads and cannot be shut down, wait until next shutdown period and then follow Step 4 procedure. If engine can be stopped, follow procedures in Step 4.</p>
<p>4. LOW OIL PRESSURE. Engine shuts down. NOTE: Also see Step 5.</p>	<p>Indicates engine oil pressure has dropped below an acceptable level, and the unit has stopped. Check oil level, lines and filters. If oil system is stable, but oil level is low, replenish. Reset control and restart.</p>

<p align="center">SYMPTOM As Indicated on Display Screen</p>	<p align="center">CORRECTIVE ACTION</p>
<p>5. OVERCRANK. Engine stops cranking. Or Engine runs, shuts down, and LOW OIL PRESSURE.</p>	<p>Indicates possible fuel system problem.</p> <ul style="list-style-type: none"> • Check for empty fuel tank, fuel leaks, or plugged fuel lines and correct as required. • Check for dirty fuel filter and replace if necessary (See Maintenance section of Engine Manual). • Check for dirty or plugged air filter and replace if necessary (See Maintenance section of Engine Manual). • Refer to Step 4. • Reset the control and restart after correcting the problem. Contact your Dealer or Distributor for service if none of the above.
<p>6. OVERSPEED. Engine runs and then shuts down.</p>	<p>Indicates engine has exceeded normal operating speed. Refer to governor adjust procedure. Contact your Dealer or Distributor for service.</p>
<p>7. UNIT NOT IN AUTO.</p>	<p>Indicates AUTO/OFF/RUN switch is in the OFF position which will prevent automatic starting if an automatic transfer switch is used. Move the AUTO/OFF/RUN switch to the AUTO position for automatic starting.</p>
<p>8. LOW FUEL. Engine continues to run.</p>	<p>Indicates diesel fuel supply is running low. Check fuel supply and replenish as required.</p>
<p>9. LOW FUEL and LOW OIL.</p>	<p>Indicates engine has run out of fuel. Check fuel level and replenish as required. See Engine Manual for fuel system priming procedure.</p>
<p>10. LOW ENGINE TEMPERATURE. Set is in standby mode but not operating.</p>	<p>Indicates engine coolant heater is not operating or is not circulating coolant. Check for the following conditions:</p> <ul style="list-style-type: none"> • Coolant heater not connected to power supply. Check for blown fuse, open circuit breaker or disconnected heater cord and correct as required. • Check for low coolant level and replenish if required. Look for possible coolant leakage points and repair as required.
<p>11. Engine starts from generator control panel, but will not start automatically or from a remote panel. Note: The AUTO/OFF/RUN switch must be in the AUTO position. Automatic or remote starting.</p>	<p>Indicates possible fault with remote start circuit. Check the following:</p> <ul style="list-style-type: none"> • Check wire to ATS. • See ATS section for further troubleshooting. • Contact your Dealer or Distributor for assistance.

<p style="text-align: center;">SYMPTOM As Indicated on Display Screen</p>	<p style="text-align: center;">CORRECTIVE ACTION</p>
<p>12. Engine will not crank.</p>	<p>Indicates possible fault with control or starting system. Check for the following conditions:</p> <ul style="list-style-type: none"> • Fault lamp on. Correct fault and reset control. • Poor battery cable connections. Clean the battery cable terminals and tighten all connections. • Discharged or defective battery. Recharge or replace the battery. • Contact your Dealer or Distributor for assistance if none of the above.
<p>13. No AC output voltage.</p>	<p>Indicates possible fault with voltage regulator.</p> <ul style="list-style-type: none"> • Verify output with another meter. If OK, check meter. If OK, check meter fuses. • Regulator fuse is blown. Replace fuse. Contact your Dealer or Distributor if voltage build-up causes fuse to blow. • Check rotating rectifier for damaged diodes. Replace all diodes if any are failed.
<p>14. No Engine Start.</p>	<p>Indicates Engine Start wires not terminated properly or Generator in OFF position.</p> <ul style="list-style-type: none"> • Check Engine Start connections. • Investigate why Engine Control Switch was put in off. • Contact your Dealer or Distributor for assistance.
<p>15. No Engine Stop.</p>	<p>Indicates Timing Cycle not complete, Engine Start wires not terminated correctly or Generator in RUN.</p> <ul style="list-style-type: none"> • Check Engine Start Timer setting. • Check Engine Start Connections. • Investigate why the Engine Control Switch was put in Manual. • Contact your Dealer or Distributor for assistance.

<p style="text-align: center;">SYMPTOM As Indicated on Display Screen</p>	<p style="text-align: center;">CORRECTIVE ACTION</p>
<p>16. ATS will not transfer to Emergency.</p>	<p>Indicates Emergency voltage or frequency not within acceptable parameters, power supply harness unplugged, limit switch harness unplugged or timing cycle not complete.</p> <ul style="list-style-type: none"> • Check Engine Start connections, generator output, and engine control switch. • Plug in power supply harness. • Plug in limit switch harness. • Check transfer to emergency timer setting. • Contact your Dealer or Distributor for assistance.
<p>17. ATS will not transfer to Normal.</p>	<p>Indicates Normal voltage or frequency not within acceptable parameters, power supply harness unplugged, limit switch harness unplugged or retransfer to Normal timing cycle not complete.</p> <ul style="list-style-type: none"> • Check utility and utility breakers. • Plug in power supply harness. • Plug in limit switch harness. • Check retransfer to Normal Timer setting. • Contact your Dealer or Distributor for assistance.